

- ① **Desligar o quadro elétrico, antes de proceder à instalação.**
Turn off the electrical panel before proceeding with the installation.
Apagar el panel eléctrico, antes de continuar con la instalación.
Éteigner le panneau électrique, avant de procéder à l'installation.

- ② **Aparafusar o suporte de fixação à parede.**
Screw the fixation holder to the wall.
Atornillar el soporte de fijación a la pared.
Visser le support de fixation au mur.

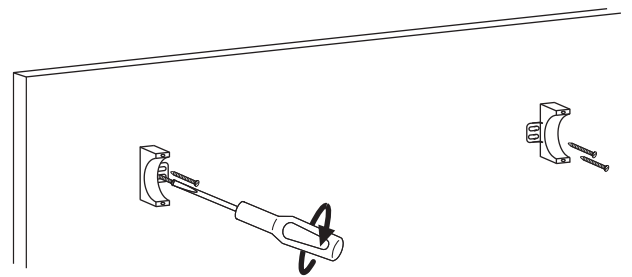
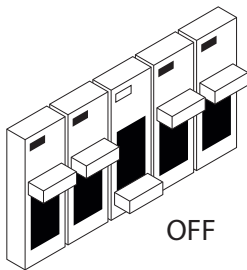

- ③ **Posicionar a tubular no suporte de fixação.**
Position the tubular in the fixing holder.
Colocar la tubular en el soporte de fijación.
Positionner le tubulaire dans le support de fixation.

- ④ **Encaixar as peças complementares do suporte de fixação.**
Fit complementary parts of the fixing holder.
Encajar las partes complementarias del soporte de fijación.
Monter les parties complémentaires de l'étrier de fixation.

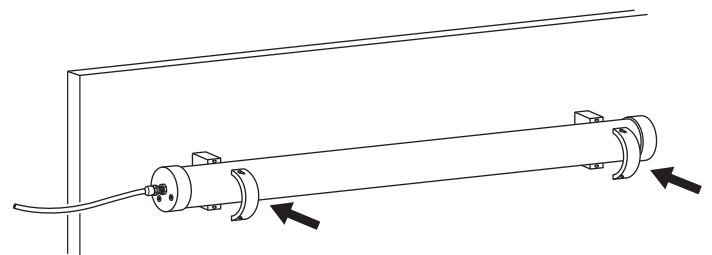
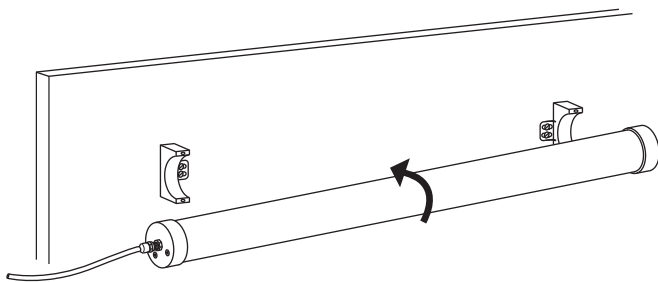

- 5 **Fechar suporte de fixação com parafusos.**
Close fixing holder with screws.
Cerrar el soporte de fijación con tornillos.
Fermez le support de fixation avec les vis.

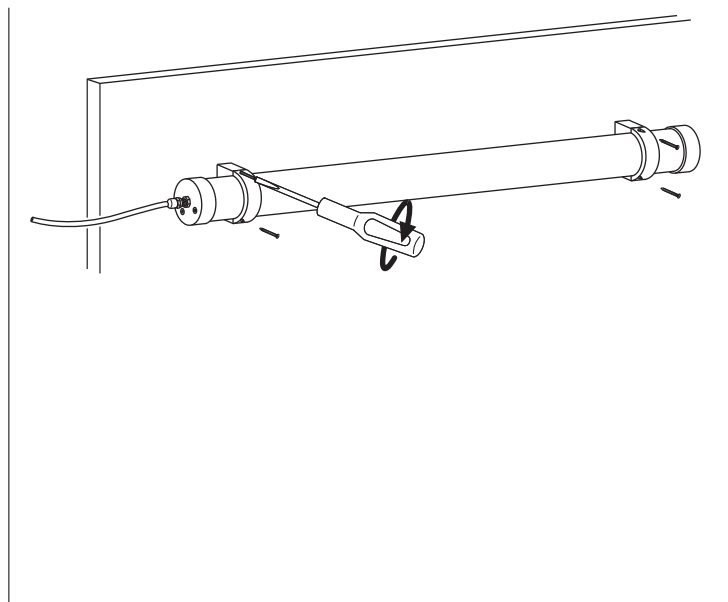

- 6 **Conectar os cabos de alimentação.**
Connect the power cables.
Conectar los cables de alimentación.
Connecter les câbles d'alimentation.

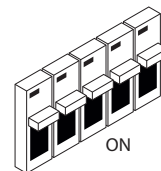
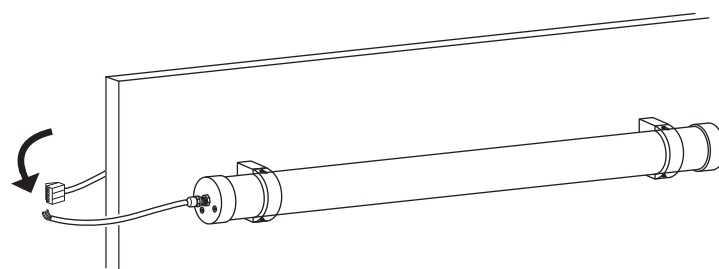

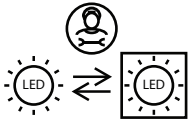

Substituição da fonte de luz (apenas LED) por um profissional.

Replacement of the light source (LED only) by a professional.

Reemplazo de la fuente de luz (solo el LED) por uno profesional.

Remplacement de la source lumineuse (uniquement la LED) par un professionnel.

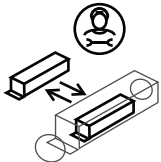

Substituição do driver por um profissional.

Replacement of the driver by a professional.

Reemplazo del driver por un profesional.

Remplacement du driver par un professionnel.

Esquema exemplificativo | Illustrative diagram | Esquema ilustrativo | Schéme d'exemple

Limpeza da luminária.

Light fixture cleaning.
Limpieza de la luminaria.
Nettoyage du luminaire.

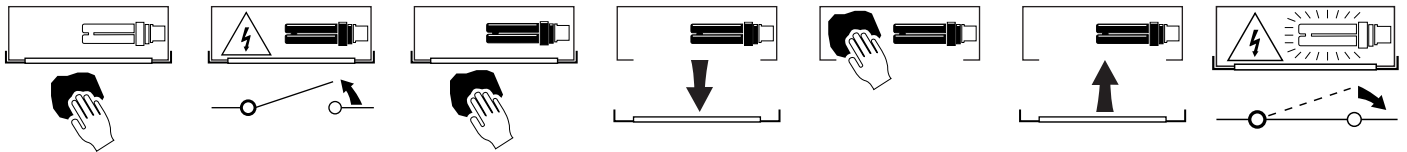

Fim da vida útil e descarte de componentes.

End of useful life and components disposal.
Fin de la vida útil y eliminación de componentes.
Fin de la durée de vie et élimination des composants.

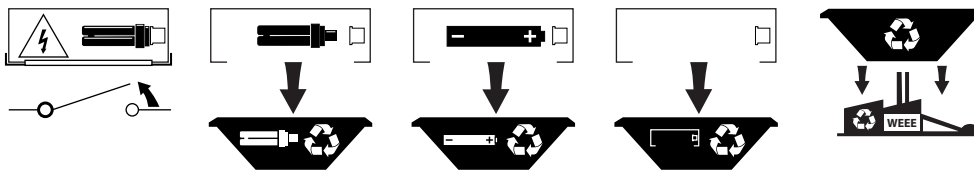

A Tromilux não se responsabiliza por quaisquer danos ou defeitos causados através da montagem e/ou utilização incorreta dos produtos, do uso de lâmpadas, fontes de alimentação ou outros componentes não indicados/recomendados, ou outros agentes externos. | Tromilux will not be held responsible for any damages or defects caused by improper assembly and/or use of the products, the use of not indicated/recommended lamps, power sources or other components, or other external agents. | Tromilux no se hace responsable de los daños o defectos ocasionados por un mal montaje y/o uso indevido de los productos, el uso de lámparas, fuentes de alimentación o otros componentes no indicados/recomendados, o otros agentes externos. | Tromilux n'est pas responsable pour les dommages ou défauts causés par un assemblage et/ou une utilisation incorrects des produits, l'utilisation de lampes, de sources d'alimentation ou d'autres composants non indiqués/recommandés, ou d'autres agents externes.