

- ① **Desligar o quadro elétrico antes de proceder à instalação.**
Turn of the electrical panel before proceeding with the installation.
Apagar el panel eléctrico, antes de continuar con la instalación.
Éteigner le panneau électrique, avant de procéder à l'installation.

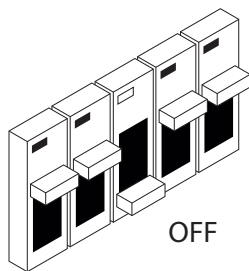

- ② **Pontos de fixação (I).**
Fixing points (I).
Puntos de fijación (I).
Points de fixation (I).

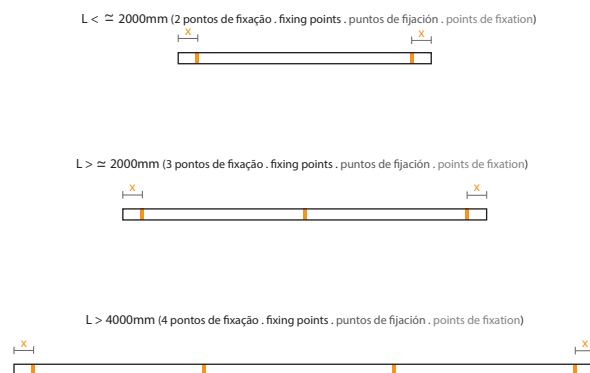

- ③ **Fazer a furação do teto com base nas medidas indicadas.**
Drill the ceiling based on the measurements indicated.
Perforar el techo en base a las medidas indicadas.
Percer le plafond en vous basant sur les mesures indiquées.

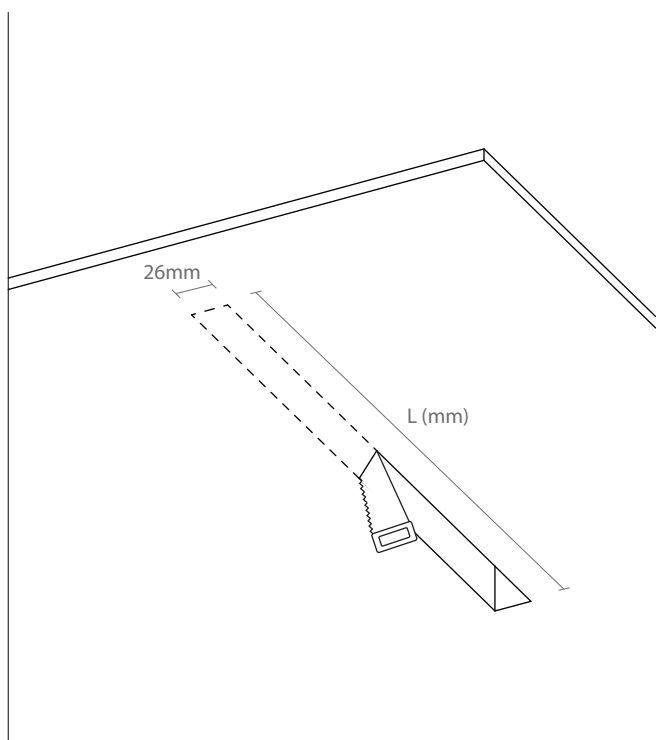

- ④ **Desencaixar o difusor e retirar a fita LED do perfil.**
Remove the diffuser and remove the LED strip from the profile.
Retirar el difusor y retirar la tira de LED del perfil.
Retirer le diffuseur et retirer la bande LED du profilé.

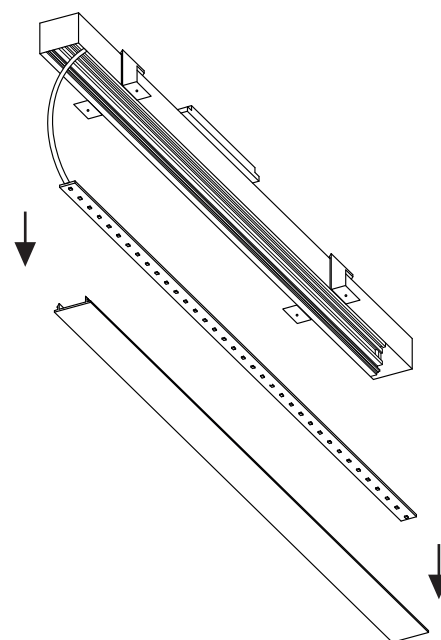

- 5 **Posicionar as molas de fixação e passá-las pela abertura no teto.**
Position the fixing springs and pass them through the opening in the ceiling.
Colocar los muelles de fijación y pasarlos por la abertura del techo.
Positionner les ressorts de fixation et les faire passer par l'ouverture dans le plafond.

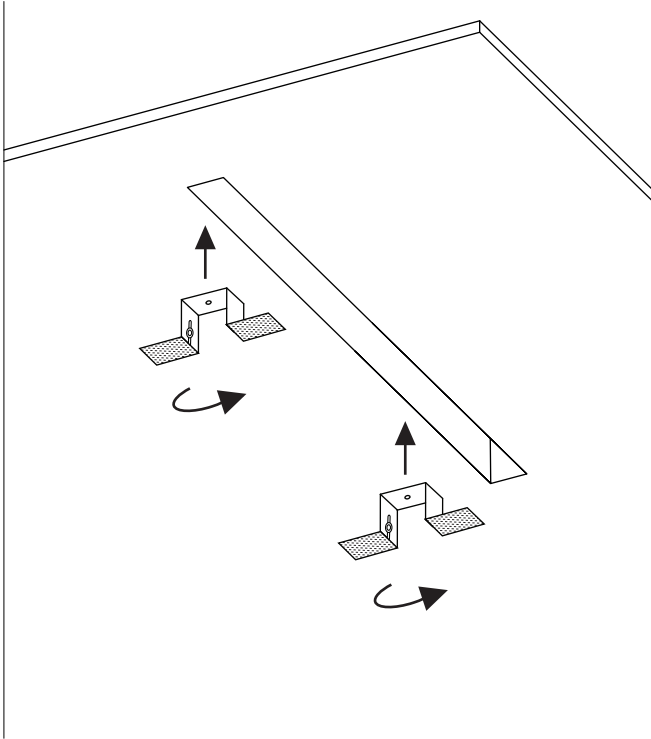

- 6 **Aparafusar as molas de fixação ao teto.**
Screw the fixing clips to the ceiling.
Atornillar los muelles de fijación al techo.
Visser les ressorts de fixation au plafond.

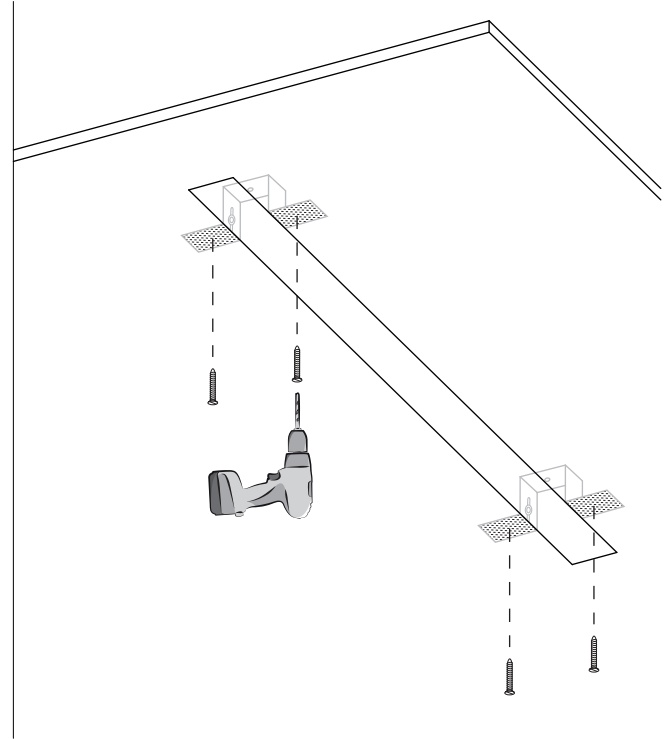

- 7 **Conetar os cabos de alimentação ao driver e colocá-lo dentro do teto.**
Connect the power cables to the driver and place it inside the ceiling.
Conectar los cables de alimentación al driver y colocarlo en el interior del techo.
Connecter les câbles d'alimentation au driver et placez-le à l'intérieur du plafond.

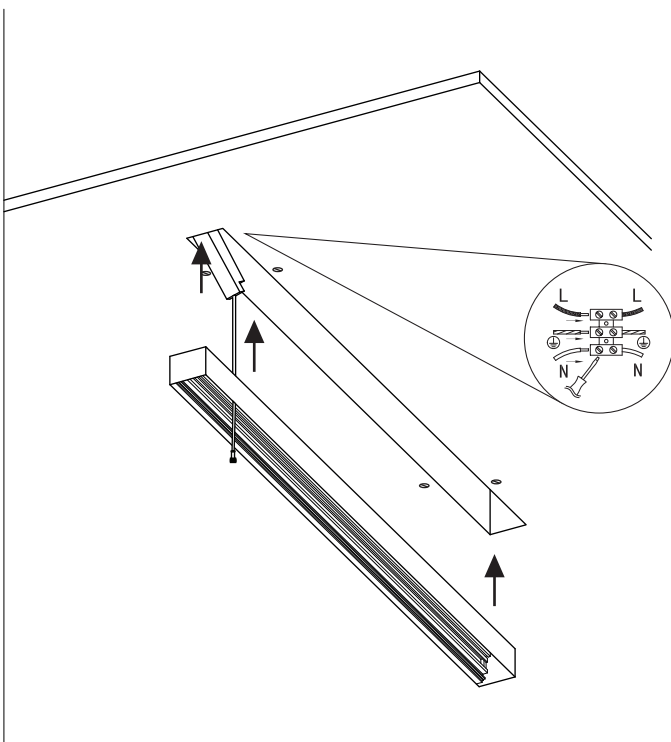

- 8 **Aparafusar o perfil às molas de fixação.**
Screw the profile to the fixation springs.
Atornillar el perfil a los muelles de fijación.
Visser le profilé aux ressorts de fixation.

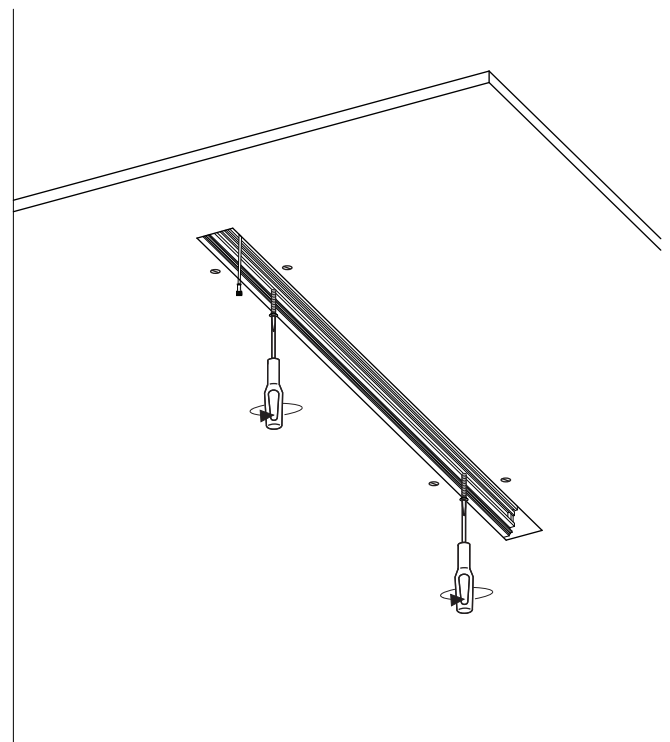

- 9 **Rematar o teto.**
Finish off the ceiling.
Recubrir el techo.
Recouvrir le plafond.

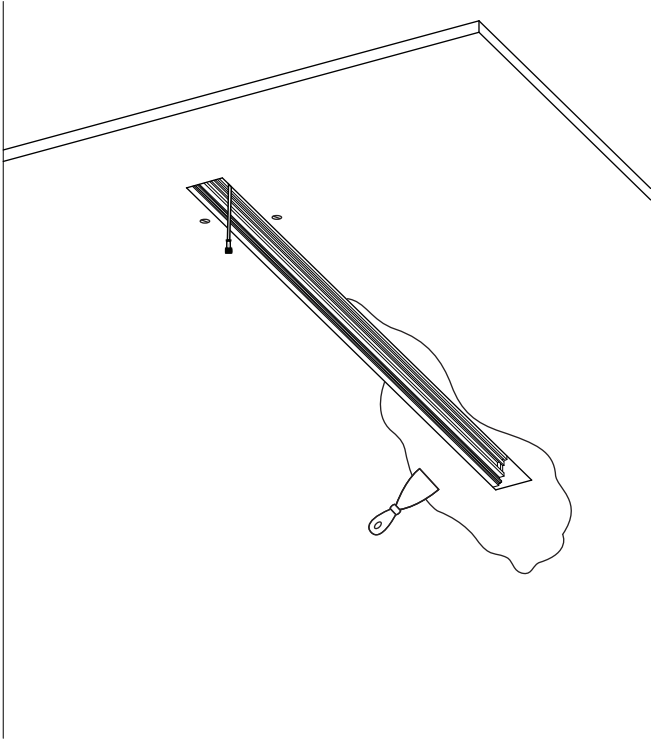

- 10 **Conetar o driver e colar a fita LED no interior do perfil.**
Connect the driver and glue the LED strip inside the profile.
Conectar el driver y pegar la tira LED en el interior del perfil.
Connecter le driver et coller la bande de LED à l'intérieur du profilé.

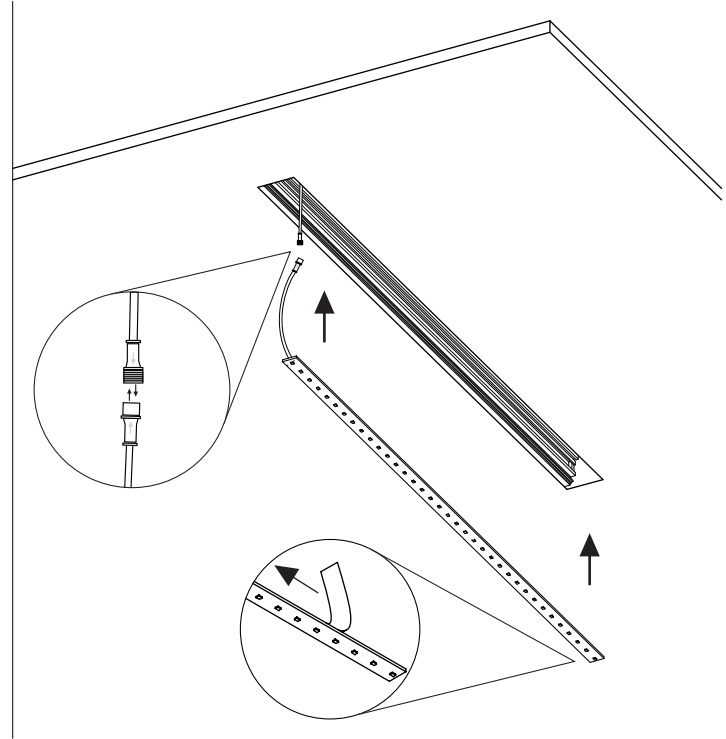

- 11 **Encaixar o difusor.**
Fit the diffuser.
Encajar el difusor.
Monter le diffuseur.

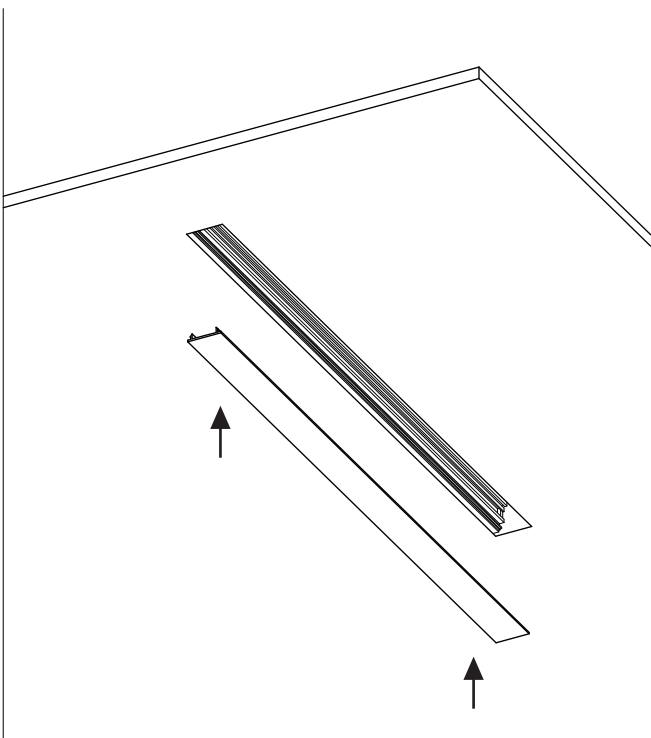

- 12 **Voltar a ligar o quadro eléctrico.**
Reconnect the electrical panel.
Reconectar el panel eléctrico.
Rebrancher le panneau électrique.

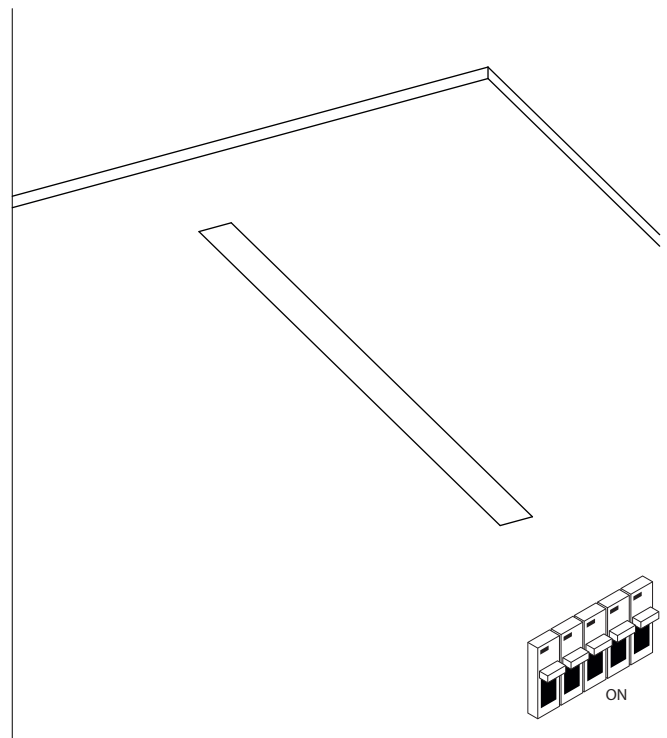

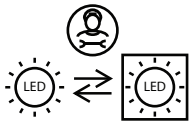

Substituição da fonte de luz (apenas LED) por um profissional.

Replacement of the light source (LED only) by a professional.

Reemplazo de la fuente de luz (solo el LED) por uno profesional.

Remplacement de la source lumineuse (uniquement la LED) par un professionnel.

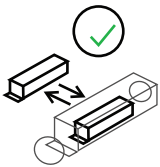

Substituição do driver por um utilizador final.

Replacement of the driver by an end user.

Reemplazo del driver por un usuario final.

Remplacement du driver par un utilisateur final.

Esquema exemplificativo | Illustrative diagram | Esquema ilustrativo | Schéme d'exemple

Limpeza da luminária.
Light fixture cleaning.
Limpieza de la luminaria.
Nettoyage du luminaire.

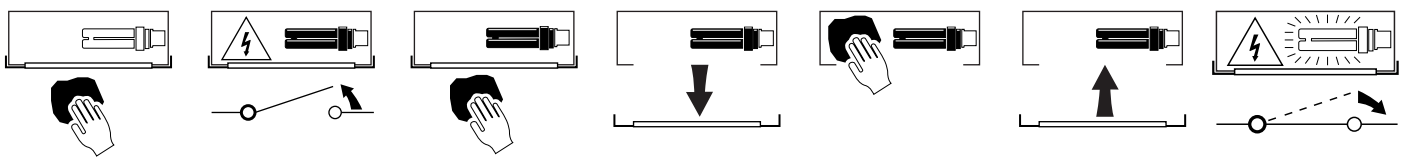

Fim da vida útil e descarte de componentes.
End of useful life and components disposal.
Fin de la vida útil y eliminación de componentes.
Fin de la durée de vie et élimination des composants.

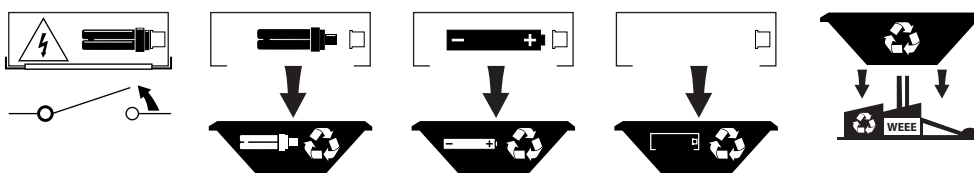

A Tromilux não se responsabiliza por quaisquer danos ou defeitos causados através da montagem e/ou utilização incorreta dos produtos, do uso de lâmpadas, fontes de alimentação ou outros componentes não indicados/recomendados, ou outros agentes externos. | Tromilux will not be held responsible for any damages or defects caused by improper assembly and/or use of the products, the use of not indicated/recommended lamps, power sources or other components, or other external agents. | Tromilux no se hace responsable de los daños o defectos ocasionados por un mal montaje y/o uso indevido de los productos, el uso de lámparas, fuentes de alimentación o otros componentes no indicados/recomendados, o otros agentes externos. | Tromilux n'est pas responsable pour les dommages ou défauts causés par un assemblage et/ou une utilisation incorrects des produits, l'utilisation de lampes, de sources d'alimentation ou d'autres composants non indiqués/recommandés, ou d'autres agents externes.